

# Brushless DC-Servomotors

with integrated Speed Controller

36,5 mNm  
17,5 W

## 3153 ... BRC

Values at 22°C and nominal voltage	3153 K	009 BRC	012 BRC	024 BRC	
Power supply electronic	$U_P$	5 ... 30	5 ... 30	5 ... 30	V DC
Power supply motor	$U_{mot}$	0 ... 18	0 ... 24	0 ... 30	V DC
Nominal voltage for motor	$U_N$	9	12	24	V
No-load speed (at $U_N$ )	$n_0$	5 200	5 100	5 200	min <sup>-1</sup>
Torque constant	$K_M$	16,22	21,8	43,59	mNm/A
Starting torque	$M_A$	42	50	50	mNm
Standby current for electronic (at $U_N$ )	$I_{el}$	0,025	0,025	0,025	A
Speed range (up to 2x $U_N$ , max, 30V)		1 000 ... 10 500	1 000 ... 10 500	1 000 ... 6 500	min <sup>-1</sup>
Shaft bearings		ball bearings, preloaded			
Shaft load max.:					
– with shaft diameter	4				mm
– radial at 3 000 min <sup>-1</sup> (3 mm from mounting flange)	30				N
– axial at 3 000 min <sup>-1</sup> (push / pull)	5				N
– axial at standstill (push / pull)	50				N
Shaft play:					
– radial	≤ 0,015				mm
– axial	= 0				mm
Operating temperature range	-25 ... +85				°C
Housing material	mounting face in aluminium, housing in plastic				
Mass	155				g

### Rated values for continuous operation

Rated torque	$M_N$	34,5	33,5	36,5	mNm
Rated current (thermal limit)	$I_N$	2,4	1,73	0,99	A
Rated speed	$n_N$	2 500	2 900	3 200	min <sup>-1</sup>

### Interface / range of functions

	... BRC
Configuration from Motion Manager 5.0	via USB Programming Adapter
Operating modes	Integrated speed control via PI controller. Setpoint Input via analog voltage input. Can optionally be operated as a voltage controller or in fixed speed mode.
Speed range	Sensorless operation, from 1000 min <sup>-1</sup>
Additional functions	Digital input as switching input for defining the direction of rotation of the motor Digital output as frequency output. Integrated current limitation to protect against thermal overload.

#### Note:

The display shows the range of possible operation points of the drives at a given ambient temperature of 22°C.

The diagram indicates the recommended speed in relation to the available torque at the output shaft.

It includes the assembly on a plastic- as well as on a metal flange (assembly method: IM B 5).

The nominal voltage linear slope describes the maximal achievable operating points at nominal voltage. Any points of operation above this linear slope will require a supply voltage  $U_{mot} > U_N$ .

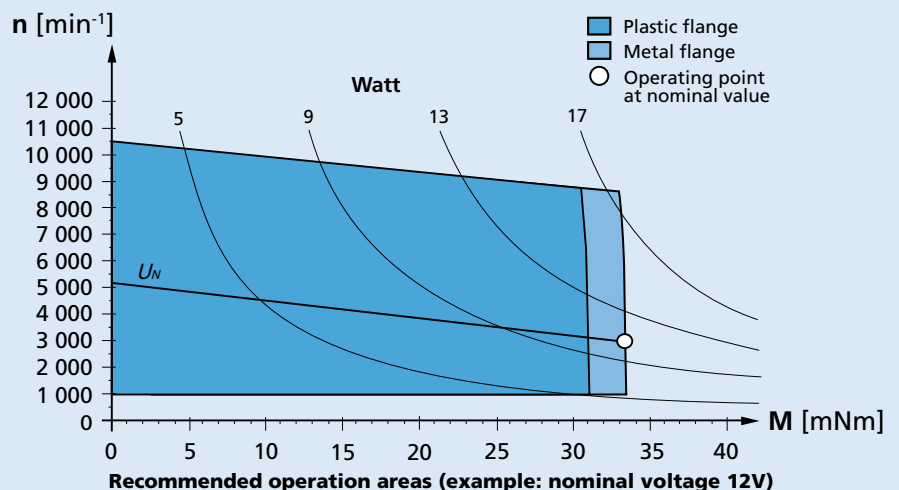

### Dimensional drawing

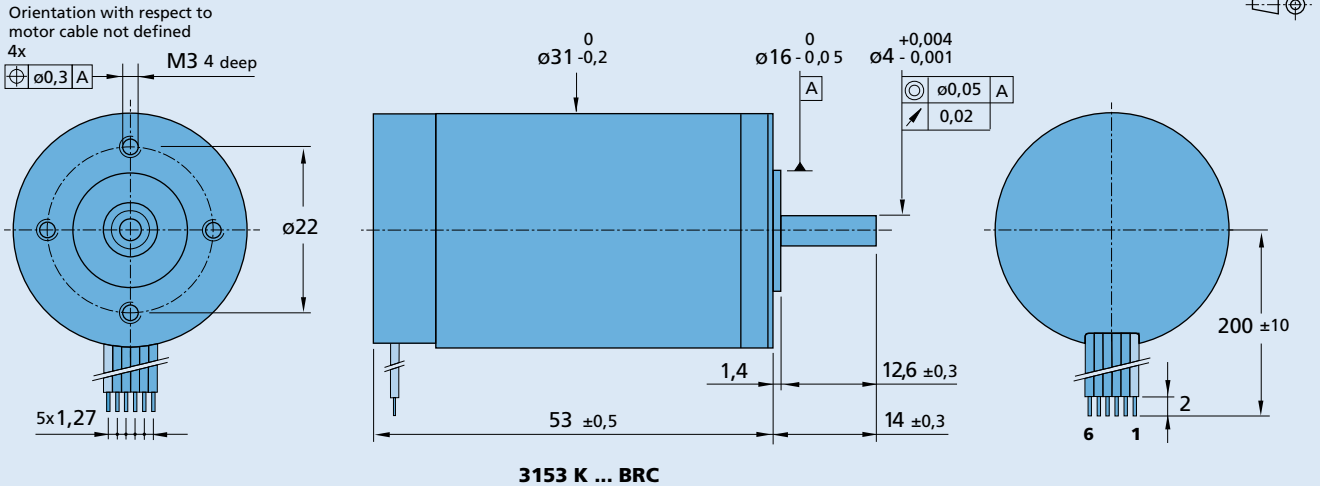

### Option, cable and connection information

Example product designation: **3153K024BRC**

Option	Type	Description	Connection			
			Name	Function	Inputs-outputs	Description
			1 (red)	$U_p$	electronic supply	5 V DC - 30 V DC
			2	$U_{mot}$	motor supply	0 V DC - $2 \times U_N$ (max. 30V)
			3	GND	ground	
			4	$U_{soll}$	Speed command	0 - 10 V DC   > 10 V DC - max. $U_p$ not defined
			5	DIR	direction of rotation	on ground or $U < 0,5 V = CCW$ , $U > 3 V = CW$
			6	FG	frequency output	(max. $U_p$ , I max. 15 mA) 3 lines per revolution
			<b>Caution:</b> Incorrect lead connection will damage the motor electronics!			
			<b>Standard cable</b> PVC ribbon cable 6 x AWG 26			
			<b>Note:</b> For details on the connection assignment, see device manual			

### Product combination

Precision Gearheads / Lead Screws	Encoders	Drive Electronics	Cables / Accessories
		Integrated	To view our large range of accessory parts, please refer to the "Accessories" chapter.