

## Encoders

magnetic Encoder, digital outputs,  
3 channels, 16 - 64 lines per revolution

For combination with  
DC-Micromotors  
Brushless DC-Motors

### Series HXM3-64

		HXM3-64	
Lines per revolution	$N$	64	
Frequency range, up to <sup>1)</sup>	$f$	32	kHz
Signal output, square wave		2+1 Index	Channels
Supply voltage	$U_{DD}$	4,5 ... 5,5	V
Current consumption, typical <sup>2)</sup>	$I_{DD}$	9	mA
Pulse width	$P$	180 ± 45	°e
Phase shift, channel A to B	$\Phi$	90 ± 45	°e
Logic state width	$S$	90 ± 45	°e
Cycle	$C$	360 ± 30	°e
Signal rise/fall time, max. ( $C_{LOAD} = 50$ pF)	$tr/tf$	60 / 60	µs
Inertia of sensor magnet <sup>3)</sup>	$J$	0,02	gcm <sup>2</sup>
Operating temperature range		-25 ... +85	°C

<sup>1)</sup> Velocity (min<sup>-1</sup>) =  $f$  (Hz) x 60/ $N$

<sup>2)</sup>  $U_{DD} = 5$  V: with unloaded outputs

<sup>3)</sup> No additional inertia for series 0620 ... B

#### For combination with Motor

Dimensional drawing A <math>\lt;L1 [mm]</math>  
0615 ... S - K1707 19,4

Dimensional drawing B <math>\lt;L1 [mm]</math>  
0620 ... B - K1674 21,5

#### Characteristics

These incremental shaft encoders in combination with the FAULHABER DC-Motors are designed for indication and control of both shaft velocity and direction of rotation as well as for positioning.

Solid state sensors and a low inertia magnetic disc provide two channels with 90° phase shift and one index channel.

The supply voltage for the encoder and the DC-Motor as well as the output signals are interfaced with a flexible printed circuit (FPC) to a 8-pin ZIF connector.

Encoder is programmable by user to 16, 32, and 64 lines per revolution by setting the CFG2 pin to high, open, or ground respectively. The input power must be cycled off and on to change the settings.

Details for the DC-Motors and suitable reduction gearheads are on separate catalog pages.

To view our large range of accessory parts, please refer to the "Accessories" chapter.

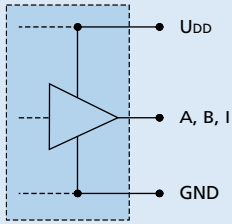
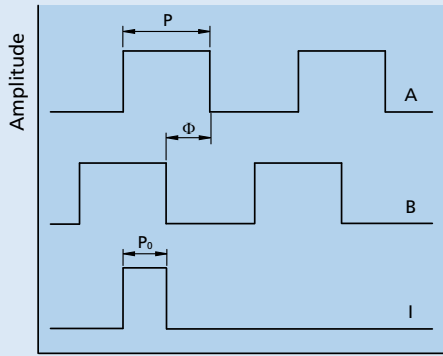
**Circuit diagram / Output signals**
**Output circuit**

**Output signals**  
 with clockwise rotation as seen from the shaft end

Caution: channel B leads channel A

**Connector information / Variants**

Example product designation: 0615N003S-K1707 HXM3-64

Option	Type	Description

**Connection Encoder and Motor**

- | No. | Function        |
|-----|-----------------|
| 1   | Motor + *       |
| 2   | U <sub>DD</sub> |
| 3   | Channel I       |
| 4   | Channel A       |
| 5   | Channel B       |
| 6   | Cfg2            |
| 7   | GND             |
| 8   | Motor - *       |



**Flexboard**  
8 circuit, 0,5 mm pitch

**Recommended connector**  
Top contact style, 8 circuits, 0,5 mm pitch, e.g.: Molex 52745

**\* Note:**  
Brushless motors have separate motor leads.

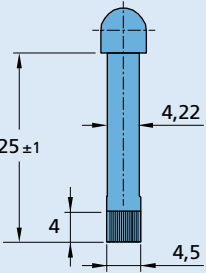
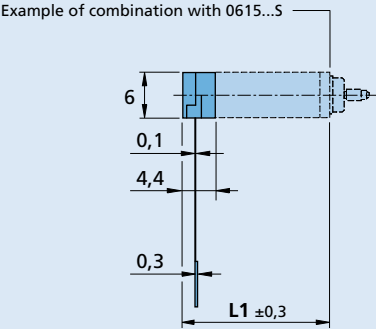
**Dimensional drawing A**

**HXM3-64**

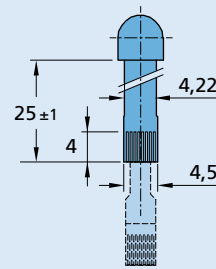
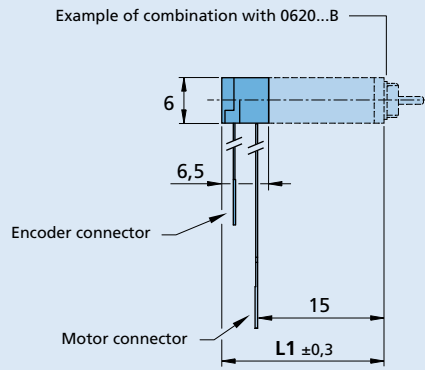
**Dimensional drawing B**



**HXM3-64**